

IS YOUR RACK COMPLIANT?

A-B-C's of RACK SAFETY

Follow the A-B-C checklist to determine if a deflection on an upright should be addressed.

A UPRIGHTS FRONTAL

Over 1/8" of frontal deflection within a span of 40"

Deflection > 1/8"

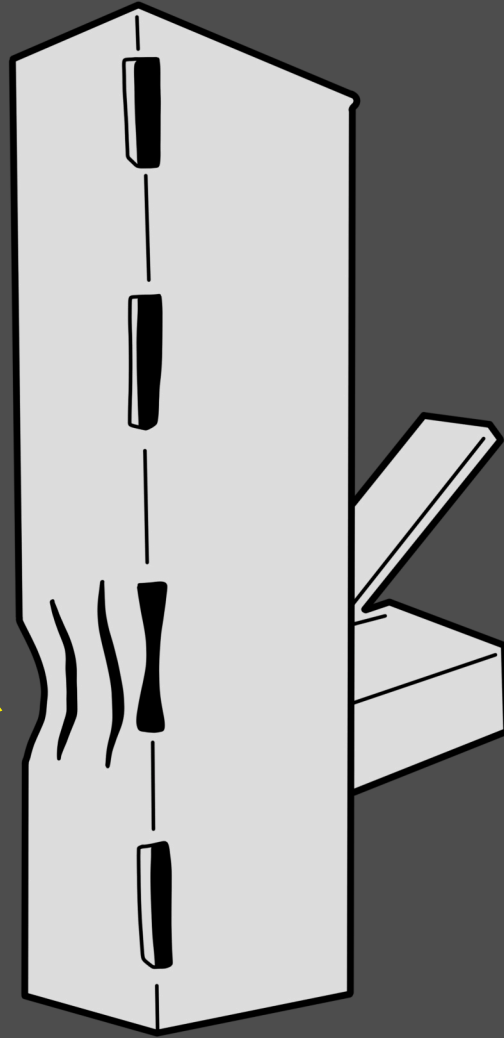

Look for other types of damage such as dents, cracks, bulges, pinched columns, and signs of corrosion.

B UPRIGHTS LATERAL

Over 1/4" of lateral deflection within a span of 40"

Deflection > 1/4"

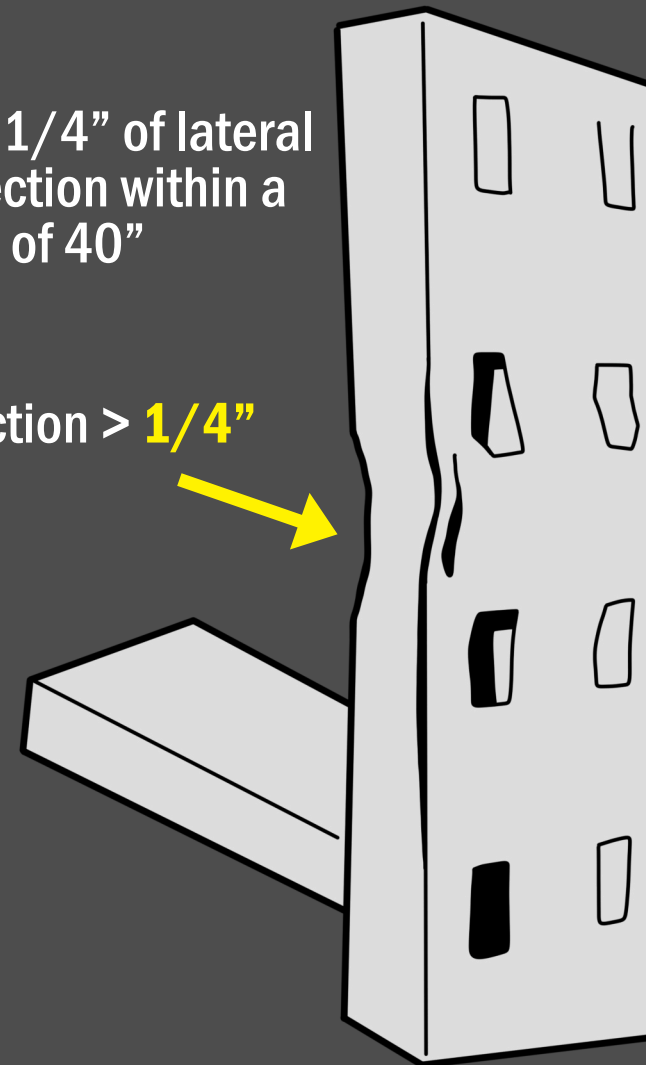

Look for damage occasionally hidden behind the beam connectors.

C BRACES HORIZONTAL & DIAGONAL

Over 3/8" of lateral deflection within a span of 40"

Deflection > 3/8"

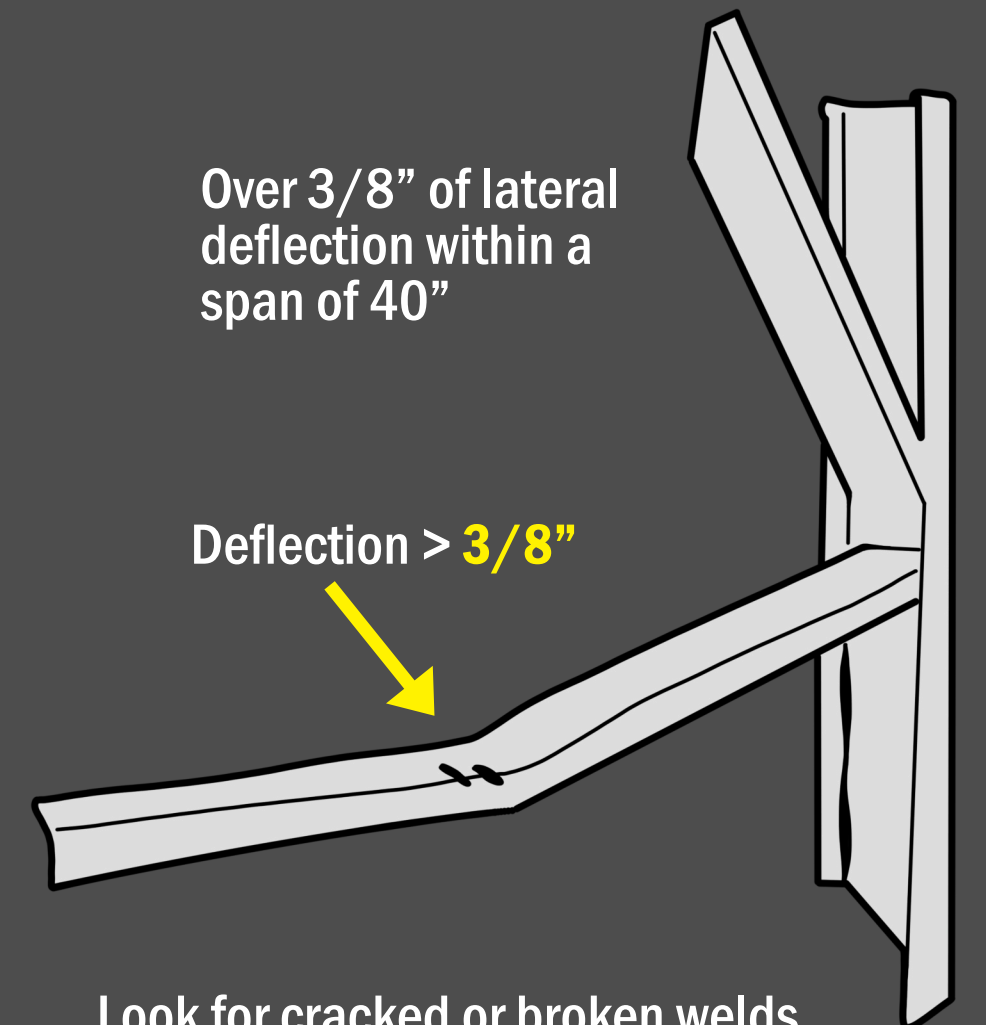

Look for cracked or broken welds between the column and the brace.

BRACES

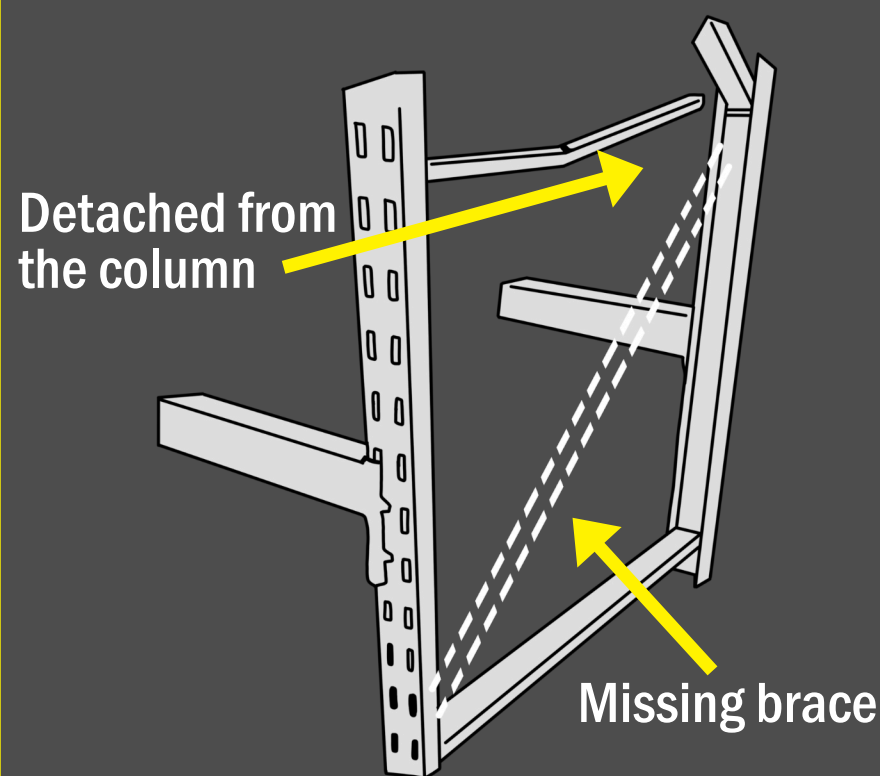

Horizontal and diagonal braces are essential to the capacity and stability of the rack.

TWISTED COLUMNS

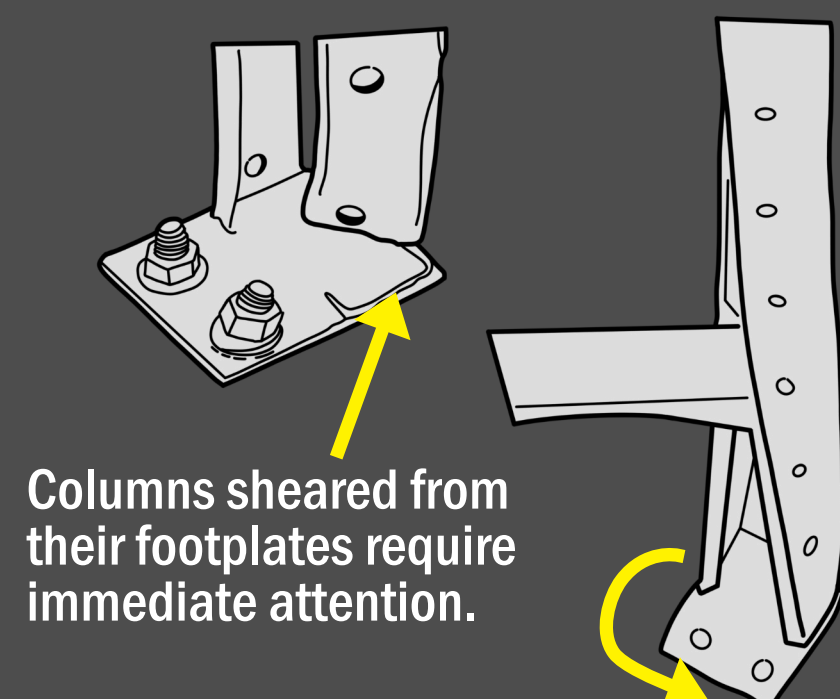

Columns sheared from their footplates require immediate attention.

Twisted columns impede the load capacity of the rack. We recommend calling an expert.

ANCHORING

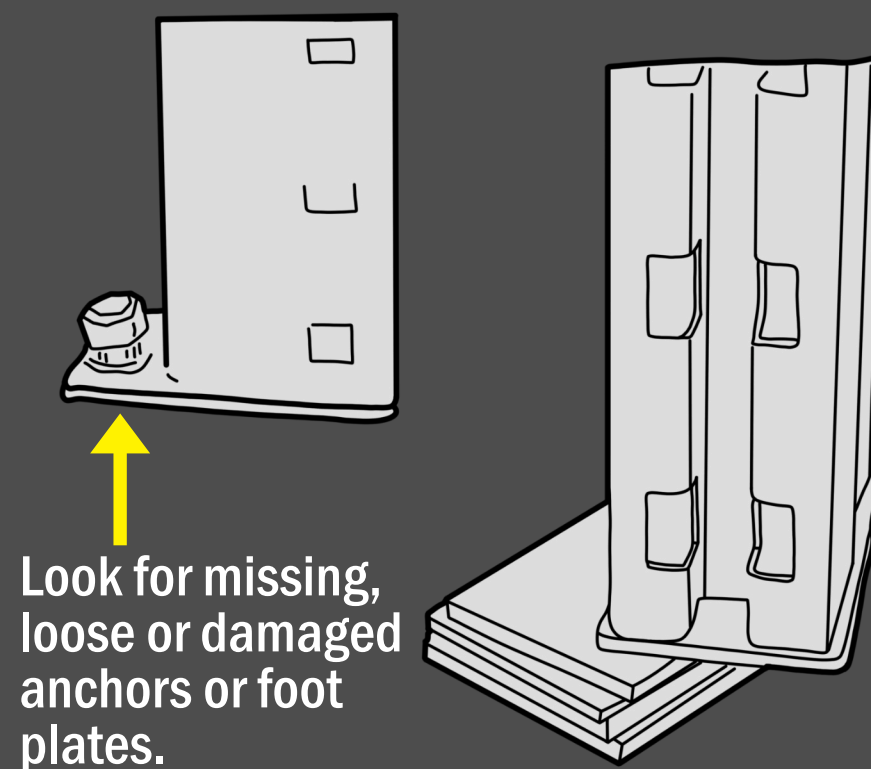

Look for missing, loose or damaged anchors or foot plates.

Shims should be well seated, secured and of equal size to the footplate.

HOMEMADE REPAIRS

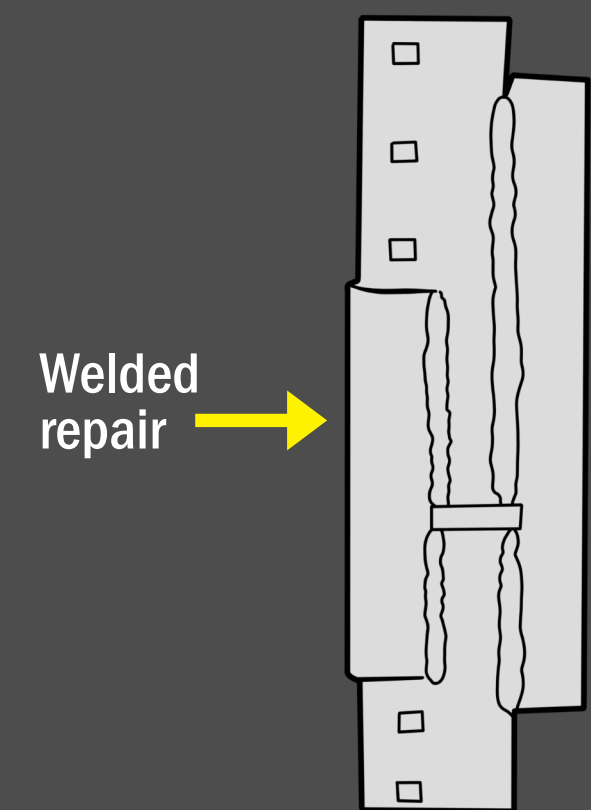

Welded repair

Any homemade or welded repairs should be replaced by an engineered repair solution.

BEAMS

Maximum allowable beam deflection:
Length (inches) / 180

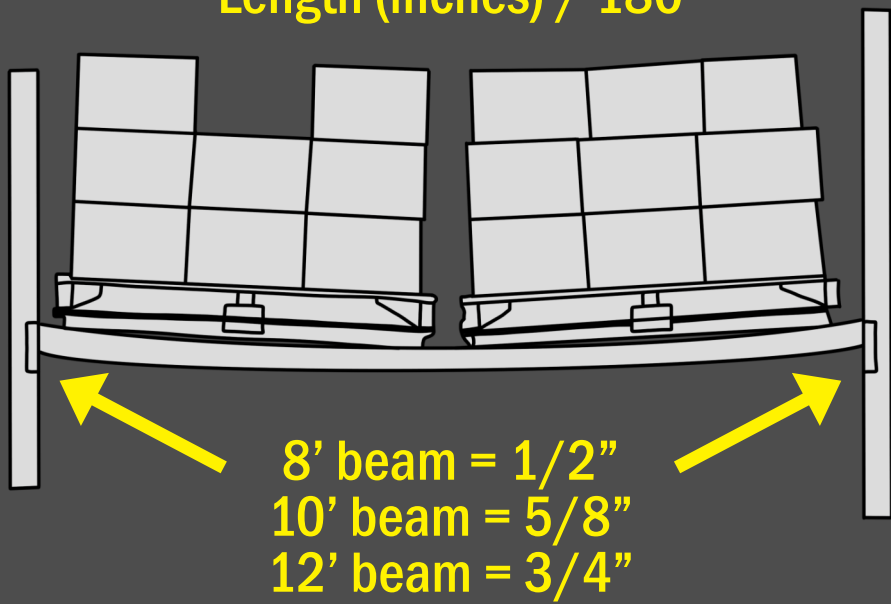

8' beam = 1/2"
10' beam = 5/8"
12' beam = 3/4"

Look for deflected, damaged, unclipped, or overloaded beams, missing safety bars, badly positioned or damaged pallets.

BEAM CONNECTORS

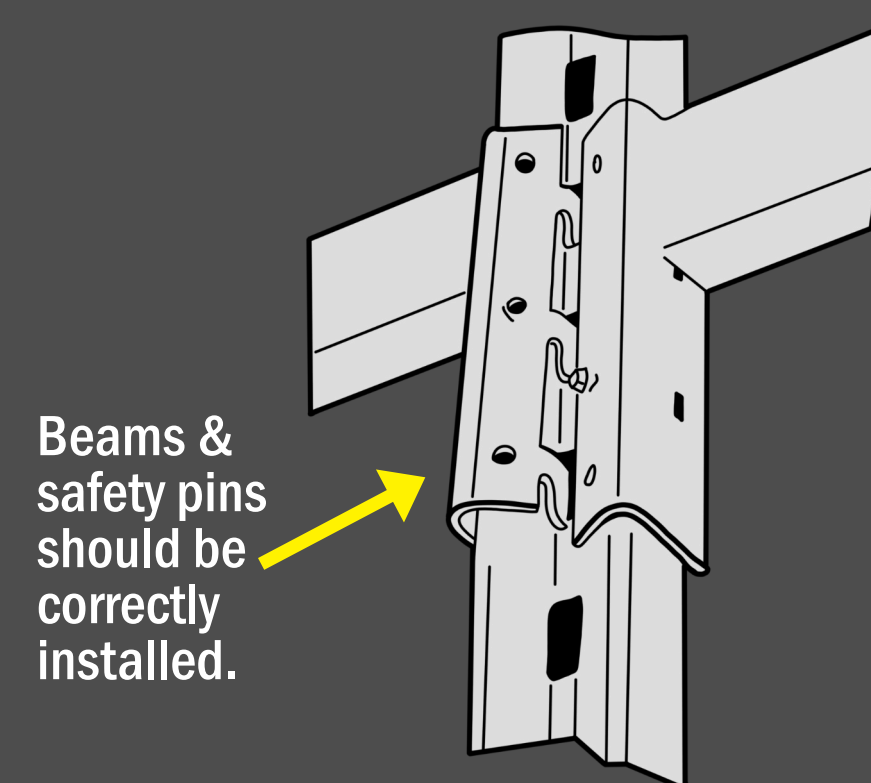

Beams & safety pins should be correctly installed.

Look for corrosion, deformations, cracks in the welds, broken connectors or missing safety pins.

OUT - OF - PLUMB

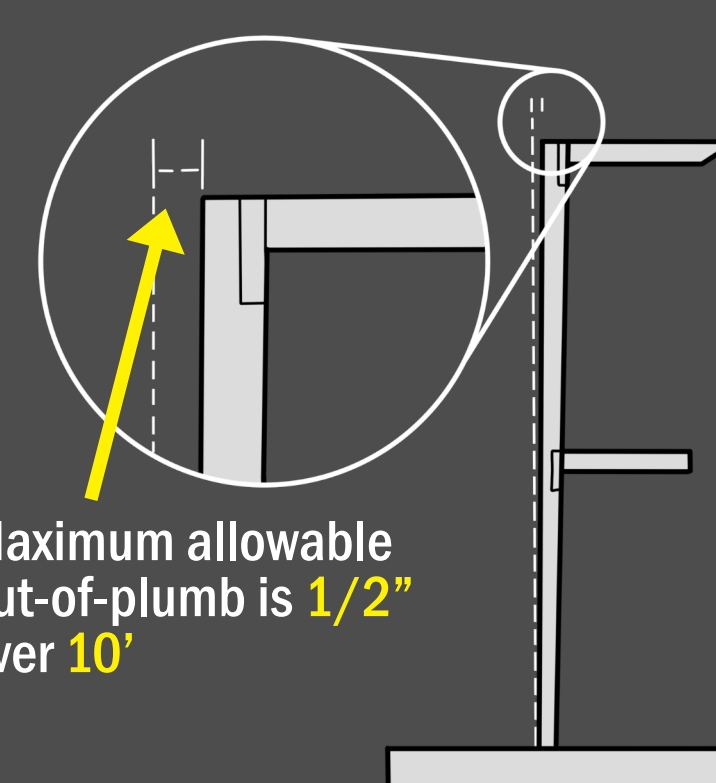

Maximum allowable out-of-plumb is 1/2" over 10'

An out-of-plumb upright means that it is not exactly vertical. Always look in the cross-aisle and down-aisle directions.

LOAD CAPACITY

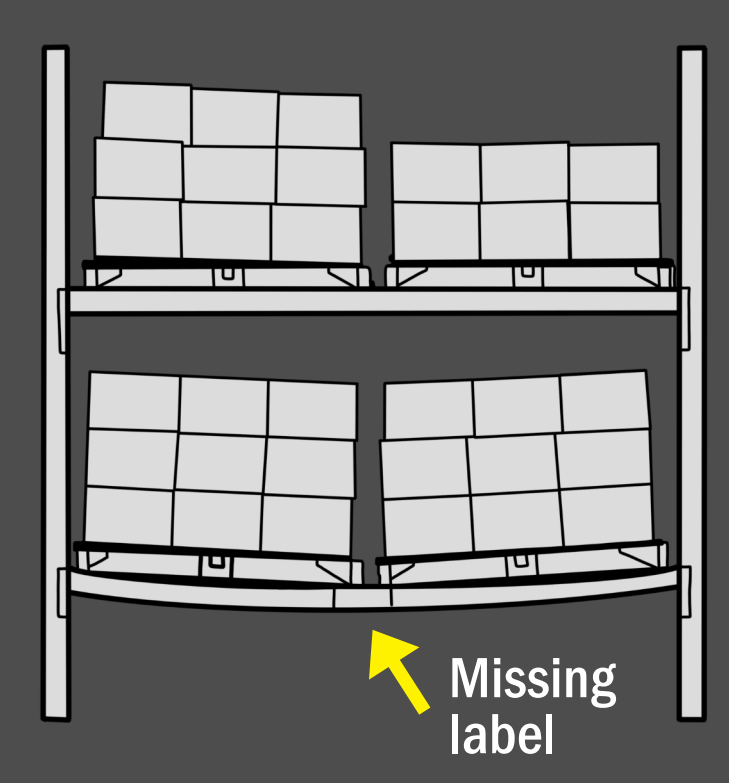

Missing label

Labels informing of maximum load capacity should be visible. Unknown load capacities need to be calculated by an engineer.

RACK SAFETY IN 5 EASY STEPS

ASSESS

Regular inspections are a great way to prevent further damage and reduce the risk of rack failure.

INFORM

All damage should be reported. Severely damaged uprights should be unloaded immediately.

PRIORITIZE

An expert in pallet rack inspection can help assign priority and course of action on the reported damage.

REPAIR

Addressing the issues and fixing the racks will ensure a safe and efficient warehouse environment.

RE-ASSESS

Racks are living entities that require regular inspections as part of an established rack maintenance program.

Do you have any damaged rack?

Various racking components are IN STOCK! Call to speak with a warehouse specialist to get your damaged rack replaced, TODAY.

THE INFORMATION PROVIDED ABOVE, BY DAMOTECH, IS FOR GENERAL INFORMATIONAL PURPOSES ONLY.



NORLIFT

MATERIAL HANDLING

(509) 535-1776

www.norlift.com