

Specifications

- **Production Speed:** Up to 35 LPH
- **Max Load Dimensions:** 53" (w) x 53" (l) x 80" (h)
- **Maximum Load Weight:** Unlimited
- **Wrap Arm Motor:** 1 HP VAC
- **Wrap Arm Drive System:** Heavy Duty Ring Gear Bearing w/10yr Warranty
- **Wrap Arm Rotation Speed:** 5 - 12 RPM
- **Frame Construction:** Formed Steel
- **Film Carriage Motor:** 1/3 HP VAC
- **Pre-Stretch:** Variable 150 - 400%
- **Containment Force:** Multi-Level Variable
- **Film Threading:** Patented S-Pattern
- **Corner Compensation:** Load Cell
- **Control Panel:** Touch Screen HMI
- **Height Sensing:** Automatic Photoeye
- **Wrapping Menus:** 12 Programmable Menus
- **Utility Requirements:** 115V 20 amps 60Hz
- **Safety:** Safety Bumper Warning Light & Alarm, CE Compliant, UL, CUL
- **Available Options:** Roping Device, Auto-Film Cutting Device, Top Platen Hold Down, 30" Film Carriage, Extended Warranty, Cold Pkg

ROTARY ROTARY 708



Key Features

- ✓ *Cube "SMART Stretch Wrapping" Technology*
- ✓ *Multi-Level Variable Pre- Stretch*
- ✓ *Multi-Level Variable Containment Force*
- ✓ *Icon Driven Touchscreen*
- ✓ *R-Connect Ready*
- ✓ *Auto Film Cutting Device*
- ✓ *Warranty*

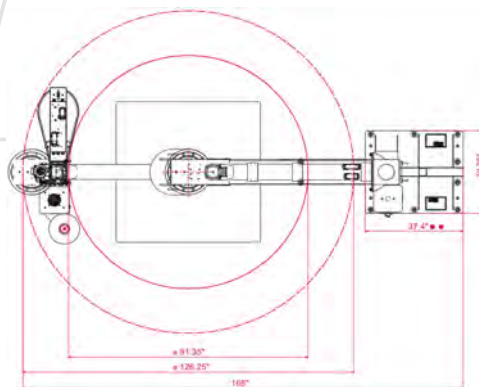

Layouts

